

© Parcel data is owned by Teranet Enterprises Inc. and its suppliers
 All rights reserved. May not be produced without permission
 THIS IS NOT A PLAN OF SURVEY

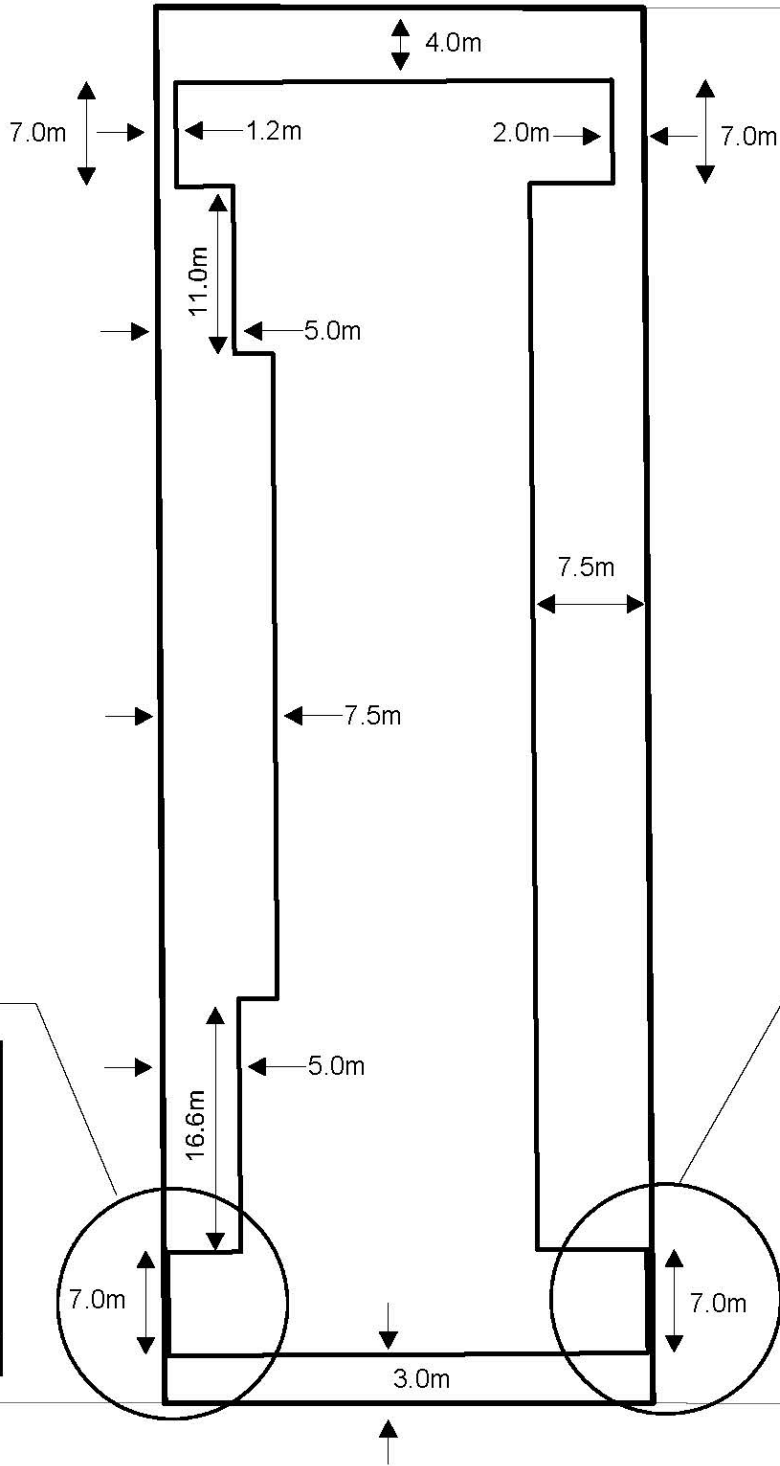

**Inset A/
Encadré A**

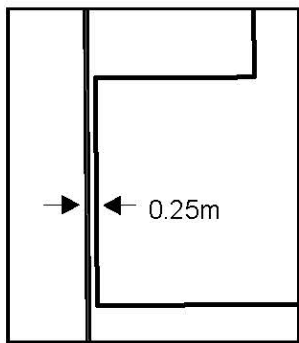

**Inset B/
Encadré B**

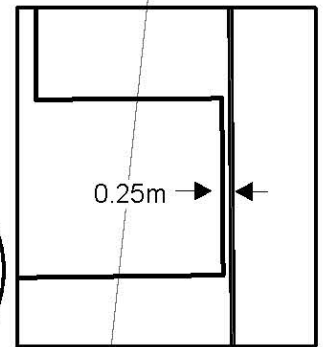

Minimum required setbacks/
Retraits minimaux requis

Mann Avenue



D02-02-13-0093 14-0521-X

M:\Zoning_Bylaw\Schedules\

Produced by Planning and Infrastructure
Portfolio

Produit par le Portefeuille urbanisme
et infrastructure

**This is Schedule 322 to Zoning By-law No. 2008-250
Annexe 322 au Règlement de zonage n° 2008-250**

This is Attachment 2 to By-law Number 2014-191, passed May 14, 2014
Pièce jointe n° 2 du Règlement municipal n° 2014-191, adopté le 14 mai 2014

Échelle
N.T.S.
Mètres



Scale
N.T.S.
Metres